

MATERIAL

Glass-fibre reinforced polyamide based (PA) technopolymer, black colour, matte finish.

STANDARD EXECUTIONS

Black-oxide steel boss, standard reamed hole, fitting to shaft by means of a supplied grub screw with hexagon socket and cup end UNI 5929-85.

- **MBT-GXX**: for gravity indicators.

- **MBT-PXX**: for positive drive indicators.

Rear flange with internal crown gear wheel in acetal resin based (POM) technopolymer. Black-oxide steel screw and anchor pin.

ERGONOMY AND DESIGN

The particular knurling on the outside rim of the knob, provided with a structure of very fine pitch, allows a safe and comfortable grip, offering the operator the possibility of operating under the most different working conditions in a sensitive and ergonomic way and simplifying the adjustment of the knob during rapid rotation (or screwing) without any unpleasant angular work for the hand and wrist.

INDICATOR CHOICE (TO BE ORDERED SEPARATELY)

To choose the indicator see the table for possible assembly with indicators.

See also "Assembly instructions" for gravity indicators type G or positive drive indicators type P.

ACCESSORIES ON REQUEST

Cover CP-XX for use without the indicator.



ELESA Original design

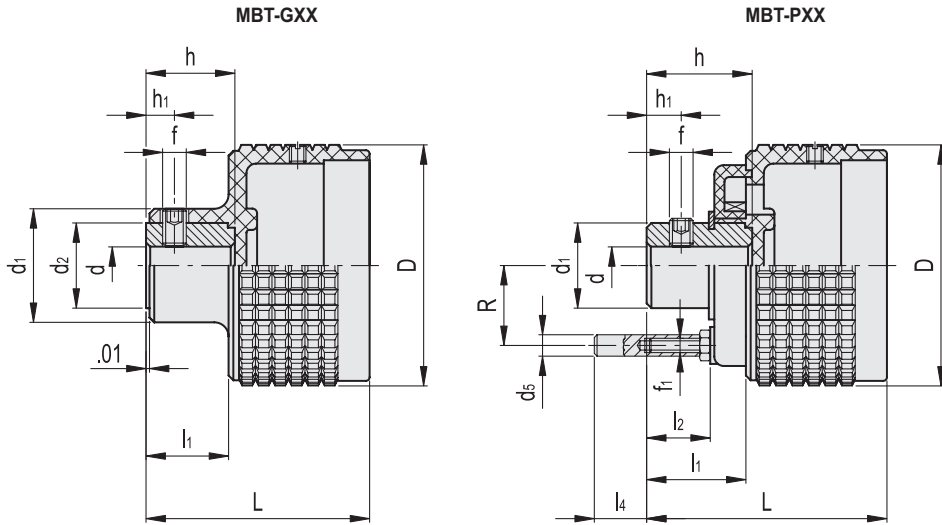

MBT-GXX

INCH

Code	Description	D	L	d	h	d1	d2	f	h1	l1	Δ	Indicators combinations
CE930001-R	MBT.60-GXX1 A-1/4	2.28	2.07	0.250	0.67	0.94	0.71	M5	0.24	0.67	0.16	GA01 - GA11
CE930005-R	MBT.60-GXX1 A-5/16	2.28	2.07	0.312	0.67	0.94	0.71	M5	0.24	0.67	0.15	GA01 - GA11
CE930051-R	MBT.80-GXX2 A-5/16	3.03	2.4	0.312	0.87	1.1	0.87	M5	0.24	0.87	0.29	GA02 - GA12 - GW12
CE930055-R	MBT.80-GXX2 A-3/8	3.03	2.4	0.375	0.87	1.1	0.87	M5	0.24	0.87	0.28	GA02 - GA12 - GW12

MBT-PXX

INCH

Code	Description	D	L	d	h	d1	d5	f	f1	h1	l1	l2	l4	R	Δ	Indicators combinations
CE930002-R	MBT.60-PXX1 A-1/4	2.28	2.17	0.250	0.81	0.71	0.24	M5	M4	0.2	0.73	0.41	0.57	0.75	0.19	PA01 - PA11
CE930052-R	MBT.80-PXX2 A-5/16	3.03	2.32	0.312	0.87	1.18	0.24	M5	M4	0.24	0.79	0.47	0.51	1.12	0.48	PA02 - PA12 - PW12

- 1
- 2
- 3
- 4
- 5
- 6
- 7
- 8
- 9
- 10
- 11
- 12
- 13
- 14
- 15
- RH

Position indicators

Position indicators